

# SMD 2835 0.5W Data Sheet

---

---

---



## India's first LED Chip – Complying International Quality and Lighting Standards.

### **Description:**

Indo Japan's SMD LED 2835 Red series products use high quality Advanced Vertical LED with Silver Alloy Bonding Technology, which improves the heat dissipation, thus enhancing the performance and reliability of LED Chips.

SMD LED 2835 series has low power consumption, wide beam angle, long product life, which makes this series suitable for all forms of lighting applications.

### **Features:**

- LM80 Compliant
- RoHS & CE Compliant
- Pb free
- Size : 2.8mm x 3.5mm x 0.65mm
- Viewing Angle : 120°
- White LED 2835
- High Lumen Output
- Low Power Consumption

### **Applications:**

- General Lighting
- Automotive Lighting
- Decorative Lighting
- Indicator Lighting
- Switch Lighting

# SMD 2835 0.5W Data Sheet



## Absolute Maximum Ratings ( $T_{\text{Soldering}} / T_a = 25^{\circ}\text{C}$ )

Parameters	Symbol	Rating	Unit
Forward Current	$I_f$	150	mA
Peak Forward Current (Duty 1/10 @10ms)	$I_{fp}$	150	mA
Power Dissipation	$P_d$	340	mW
Operating Temperature	$T_{opr}$	-40 ~ +85	$^{\circ}\text{C}$
Storage Temperature	$T_{stg}$	-40 ~ +100	$^{\circ}\text{C}$
Thermal Resistance (Junction / Soldering point)	$R_{th J-S}$	9	$^{\circ}\text{C}/\text{W}$
Junction Temperature	$T_j$	115	$^{\circ}\text{C}$
Soldering Temperature	$T_{sol}$	Reflow Soldering : 260 $^{\circ}\text{C}$ for 10 sec. Hand Soldering : 350 $^{\circ}\text{C}$ for 3 sec.	

Note:

1. The products are sensitive to static electricity and must be carefully taken when handling products.

# SMD 2835 0.5W Data Sheet

---

---

---



Parameter	Symbol	Min.	Typ.	Max.	Unit	Condition
Luminous Flux (mcd)	$\Phi$	1600	----	1800	mcd	$I_f = 60\text{mA}$
Wavelength	WLD	620	622	625	nm	$I_f = 60\text{mA}$
Forward Voltage(2)	$V_F$	2.0	----	2.35	V	$I_f = 60\text{mA}$
Viewing Angle	2 $\theta$ 1/2	----	120	----	deg	$I_f = 60\text{mA}$
Reverse Current	$I_R$	----	----	10	$\mu\text{A}$	$V_r = 5\text{V}$

## Notes:

1. Tolerance of Luminous flux:  $\pm 11\%$ .
2. Tolerance of Forward Voltage:  $\pm 0.1\text{V}$ .
3. Tolerance of Colour Rendering Index:  $\pm 2$

# SMD 2835 0.5W Data Sheet



## Relative Luminous Intensity vs Junction Temperature

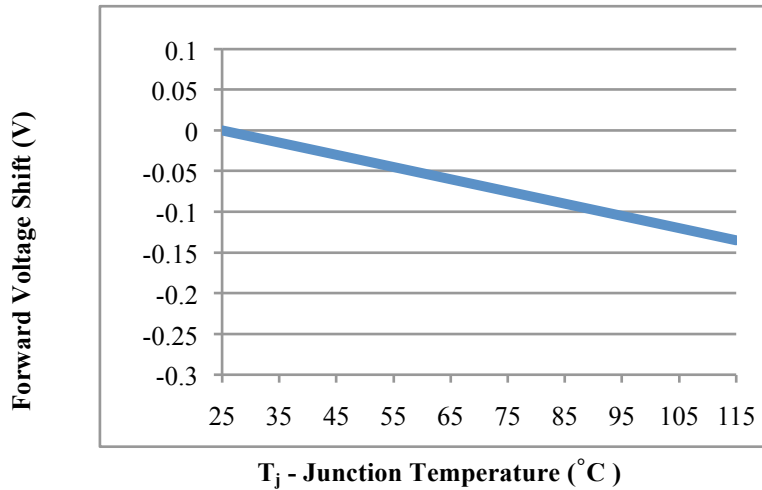

## Forward Current vs Relative Luminous Intensity

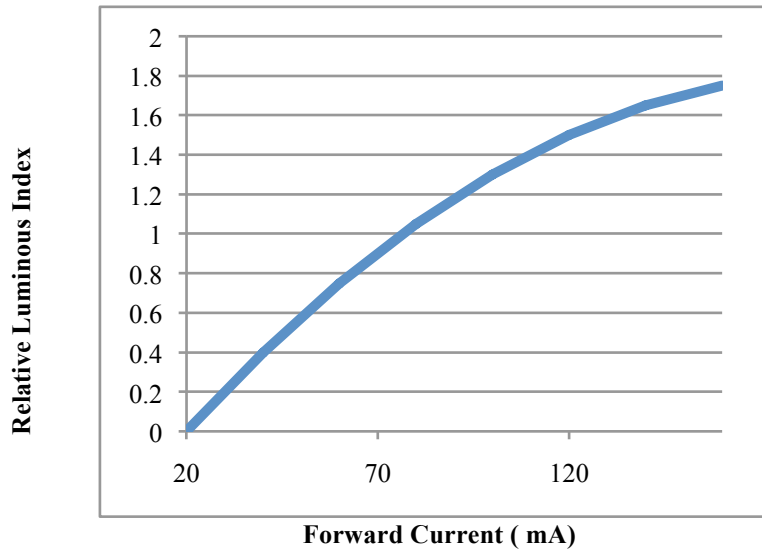

# SMD 2835 0.5W Data Sheet



## Relative Luminous Intensity vs Junction Temperature

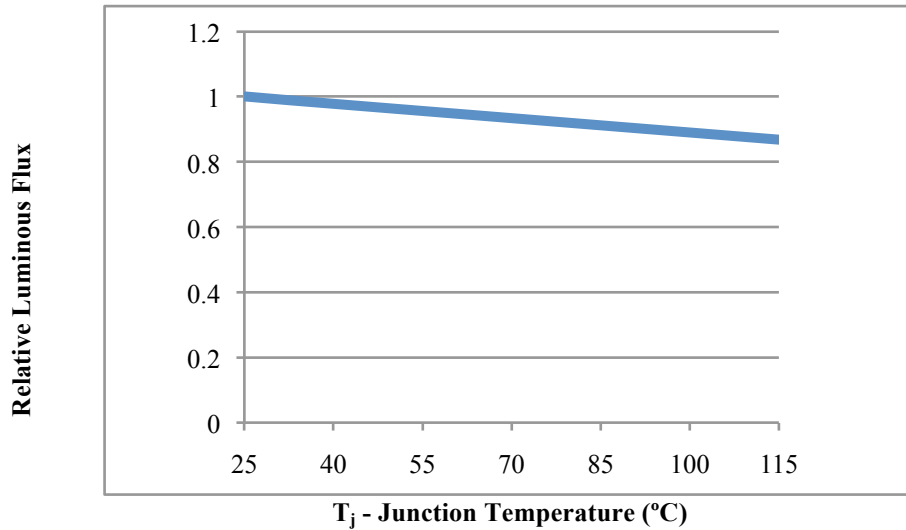

## Forward Current vs. Forward Voltage

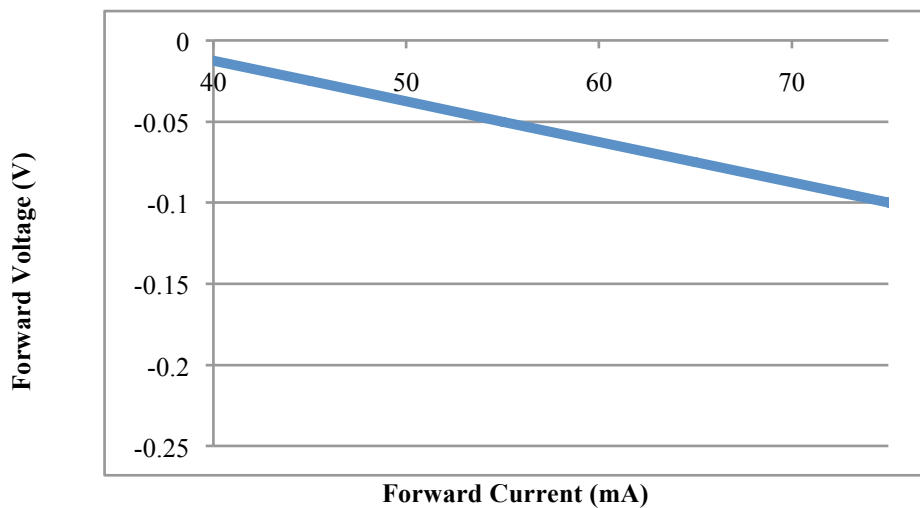

# SMD 2835 0.5W Data Sheet



## Max Driving Forward Current vs Soldering Temperature

$R_{th\ j-S=30}$  °C/W

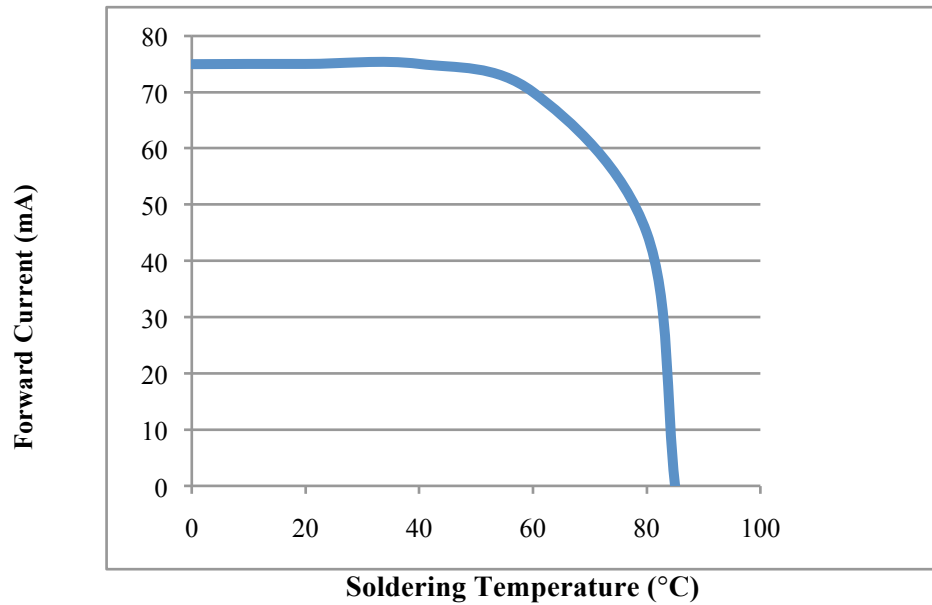

# SMD 2835 0.5W Data Sheet



## Package Dimension

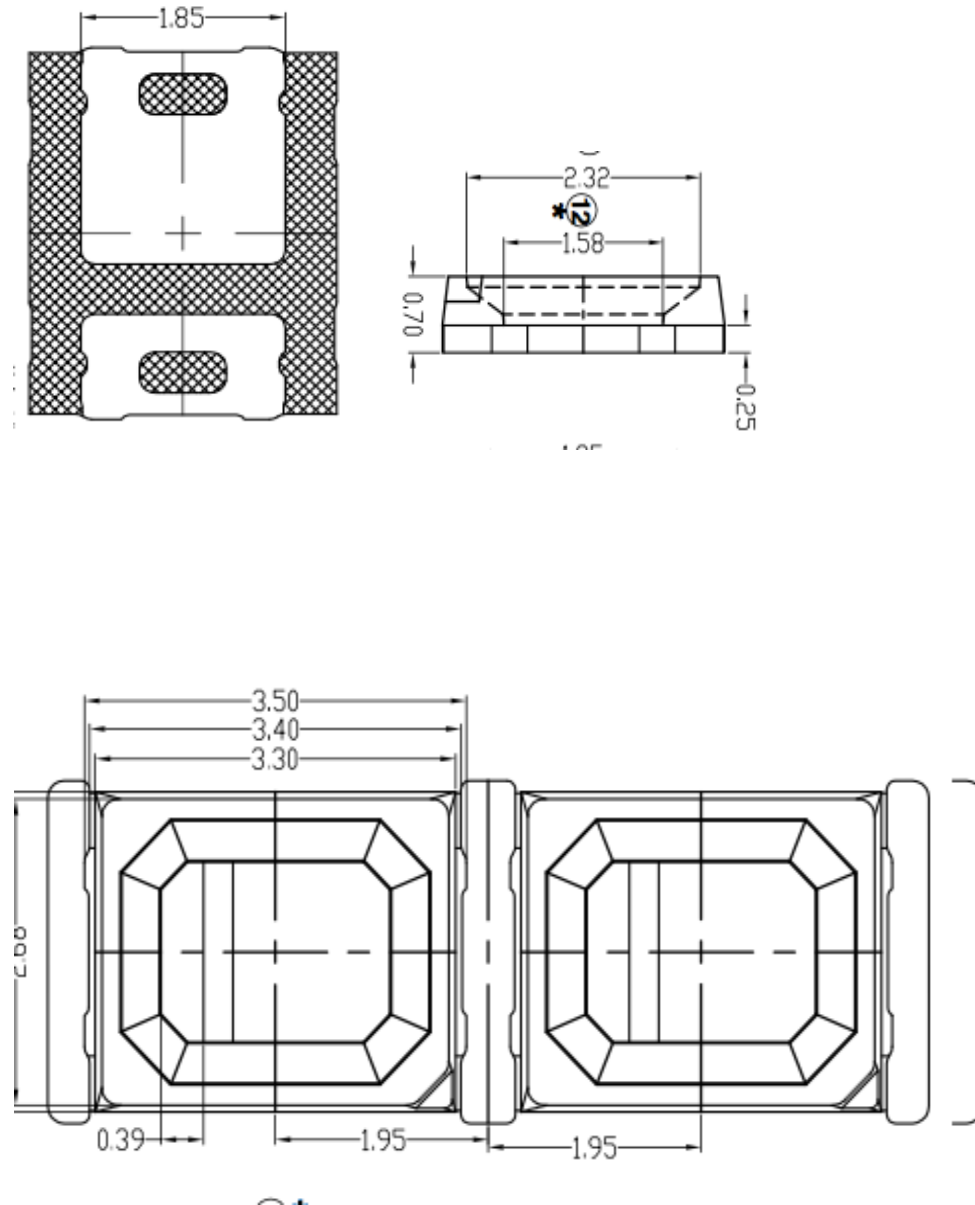

Note:

Tolerance unless mentioned is  $\pm 0.15$  mm; Unit = mm

IJ7575(4)R625NMSMD2835

# SMD 2835 0.5W Data Sheet



## Reel Dimensions

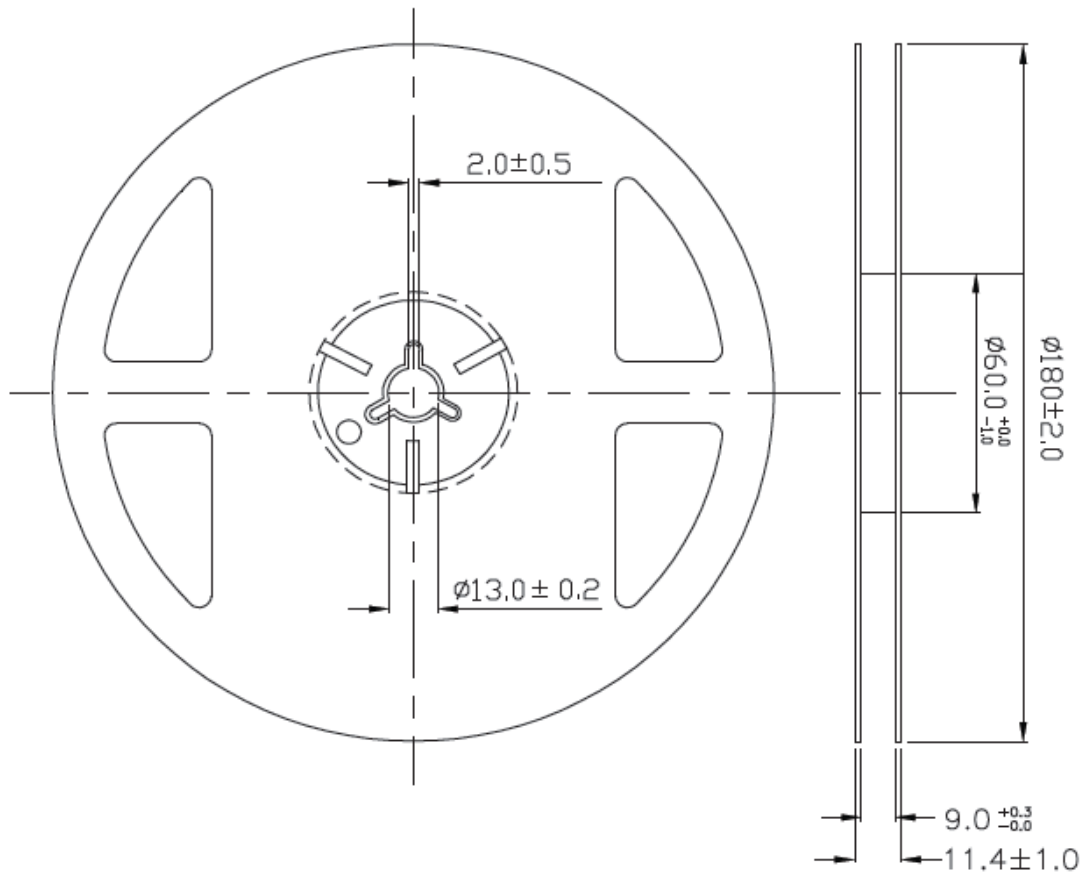

Note:

Tolerances unless mentioned  $\pm 0.1$  mm. Unit = mm



# SMD 2835 0.5W Data Sheet



## Moisture Resistant Packing Process

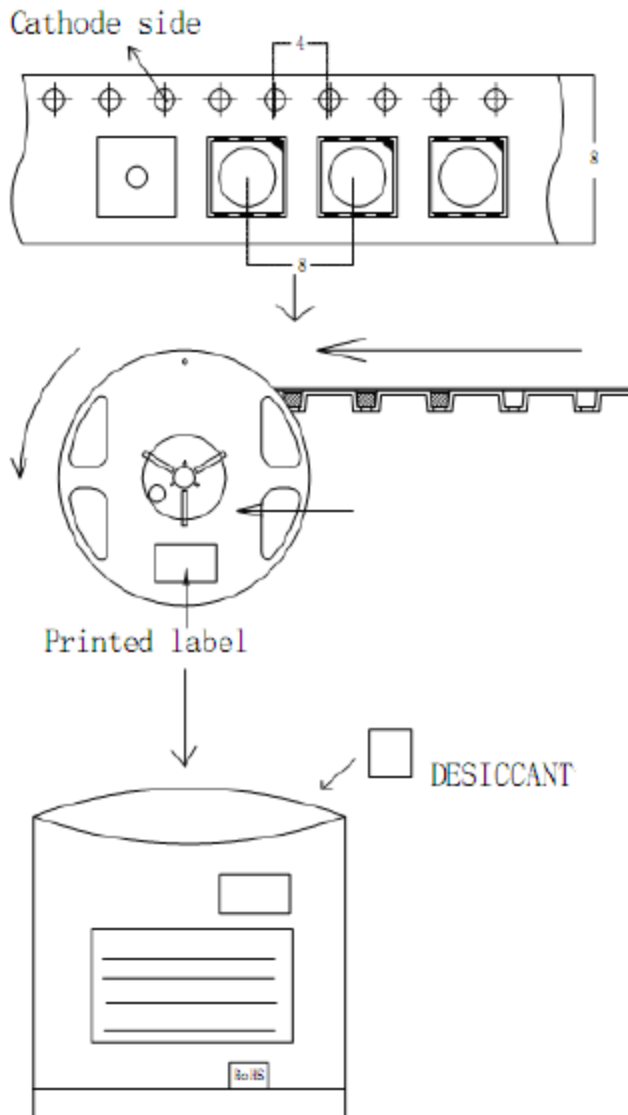

# SMD 2835 0.5W Data Sheet

---

---

---



## Notes for Reflow Soldering

- Reflow soldering should not be done more than twice.
- To ensure the reliability, quality and high performance the LED's have been encapsulated with silica gel. It not recommended to put any kind of pressure on the Chip.
- Use of high precision nozzles to avoid any sort of damage to Chips is recommended
- Use of anti-static apparels while operating on LED Chips is recommended
- Ensure high quality earthing/ground wiring.

## Notes for Hand Soldering

- Hand Soldering Parameters - 300°C for not more than 3 seconds
- Hand Soldering shouldn't be done more than once.
- Avoid using sharp objects for compressing LEDs
- Use of anti-static apparels while operating on LED Chips is recommended

## Storage

### Before opening vacuum packing

- LEDs can be stored for one year under temperature and humidity not exceeding 30°C and 60% RH.

### After opening vacuum packing

- The LED's floor life is 168 Hrs under 30°C or less and 60% RH or less. Unused LEDs should be stored in moisture proof packages.